

Specification

- ◀ Extrude aluminum casting for harsh environment
- ◀ Wire: #22AWG with 22" armored cable
- ◀ Longer cable available on request
- ◀ Optional " L " bracket
- ◀ Resistor, Diode and Supervisory Loop available on request

BSD-3020



Dimension

(Unit:mm)

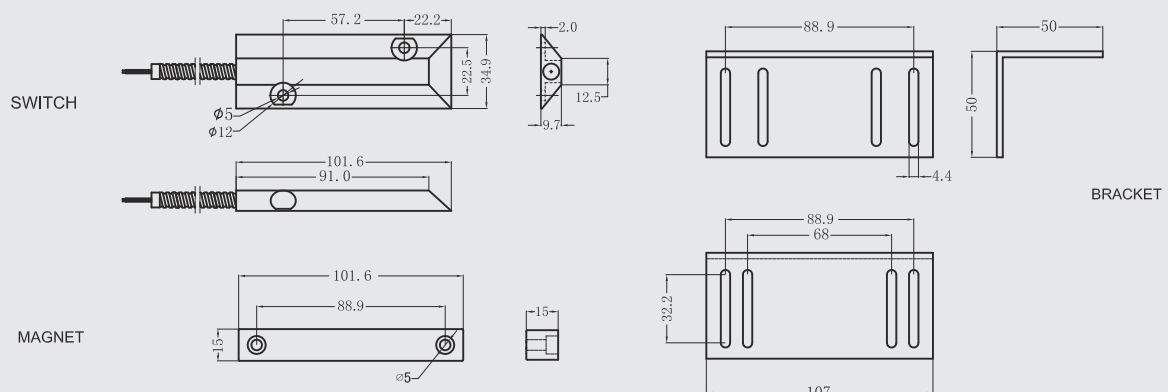

Order Information

Part Number	Loop Type	Reed Form	Closed Gap [Inch(mm)]	Departure Gap [Inch(mm)]	Maximum Initial Contact Resistance (Ohm)	Maximum Contact Rating (W)	Maximum Switching Voltage (VDC)	Maximum Switching Current (A)	Certification
BSD-3020	Closed	N/O	2.6 (65)	2.66 (66)	0.150	7.5	100	0.4	
BSD-3020WG	Closed	N/O	3 1/4 (80)	3.5 (88)	0.150	7.5	100	0.4	
BSD-3020A	Open	N/C	2 1/2 (65)		0.150	3	30	0.2	
BSD-3020C	Closed & Open	N/C	2 1/2 (65)		0.150	3	30	0.2	

* These magnetic contact switches shall be installed so that a door or other movable opening cannot be opened more than 2 inches (51mm) without initiating an alarm. Switches exceeding 2 inches can not be installed per UL681-the Standard for installation and Classification of Burglar and Holdup Alarm